

LKF1130-2

COMBINATION CORE RACK BAR DIPS CHIN UP TECHNICAL SPECIFICATIONS

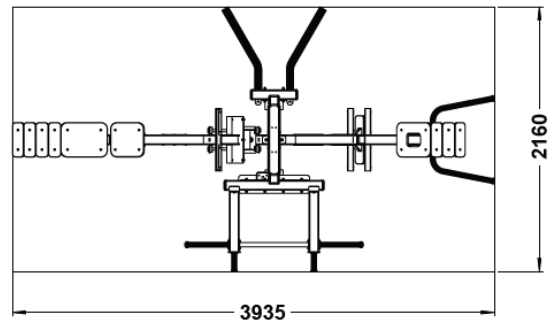

Safe Settlement Area Measure

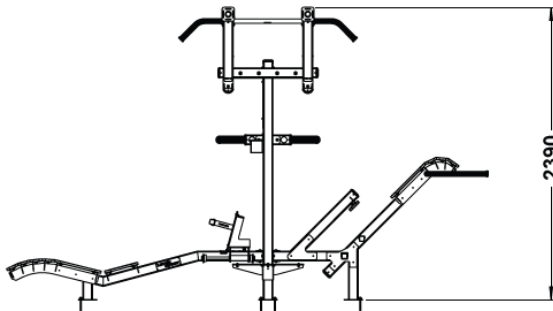
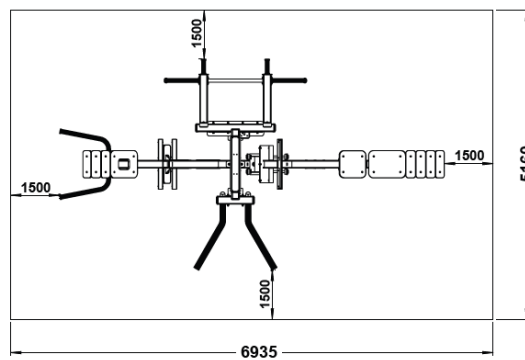

1. SCOPE

This specification covers the technical characteristics of the mechanical COMBINATION CORE RACK BAR DIPS CHIN UP machine, designed for use in outdoor sports areas, which targets the lower and upper body muscles.

2. GENERAL FEATURES

All metal parts shall be sandblasted.

The machines shall include a compartment for users to store their phones and drinks.

Each machine will feature a QR code providing access to a video explaining the correct use and operating principle of the product.

Each part will be packaged to prevent friction and scratches during transport.

The products will not have any sharp edges or surface details that could harm the human body during use. Contact points will consist of rounded lines and curves.

3. SURFACE TREATMENTS AND PAINT

Oil, rust and dirt on metal surfaces will be cleaned using a pressurised air spraying method.

The material surface will be sandblasted to open pores, ensuring better adhesion of the zinc primer and paint.

After sandblasting, all metal surfaces will be painted with zinc primer-coated electrostatic paint.

4. MECHANICAL SYSTEM AND BODY STRUCTURE

Square profiles measuring 80 x 80 x 4 mm will be used in the main body of the machine.

Rectangular profiles measuring 40 x 80 x 4 mm will be used in the moving load arms.

The shaft connecting the main body to the load arms will have a diameter of Ø40 mm.

The moving load arms will be connected to the main body with self-sealed bearings.

Surface-coated bearings numbered 6206 will be used.

The bearing systems will be protected against water, dust and external factors by polyamide-based covers produced by plastic injection moulding.

The machine will be manufactured for use by multiple persons.

5. SAFETY AND ERGONOMICS

Ø72x52 mm rubber buffers will be used to prevent impact situations.

To prevent metal-to-metal contact, 45x68x35 mm elliptical rubber buffers will be mounted on 40x80 profiles.

For user safety, half-circle, square or elliptical polyamide covers will be fitted to the ends of the 40x80 – 80x80 profiles.

6. SEAT AND ADJUSTMENT MECHANISM

The footrest platform will be adjustable according to the user's height.

The adjustment mechanism will operate on sliding bearings and Ø20 mm stainless steel pins.

Locking holes and a stainless steel safety pin will be provided for height adjustment.

Metal parts with pins will be manufactured from 2 mm CrNi 304 stainless steel sheet.

7. SUPPORTS AND HANDLES

The back, chest and seat platforms will be manufactured from vandal-resistant 19 mm thick UHDPE (Ultra High Density Polyethylene) material.

The handrails will be manufactured from Ø34 and 48*3 mm tubing. To prevent hands from slipping on the handrails, a PVC-enhanced product containing synthetic rubber, which is unaffected by adverse weather conditions and sunlight, will be used.

8. DIMENSIONS AND ASSEMBLY

The passive (closed) dimensions of the machine shall be at least 790 mm width x 3935 mm length x 1165 mm height.

The product shall be fully demountable for transport.

The products shall be manufactured in accordance with EN16630 standards.